

SNG High Performances Green Microchip Series



KEY FEATURES

- Repetition rate up to 70 kHz
- Ultrashort pulses down to 500 ps
- Multi-kW peak power
- Excellent beam quality – TEM00, $M^2 < 1.2$
- Efficient, air-cooled
- Sealed package, extremely long life

For generating high peak power green pulses of a few hundred picoseconds, microchip lasers are economical, compact, and reliable. The 532nm pulses are produced by harmonic conversion from the IR systems, the same compact sealed package being used for either wavelength.

Microchips are also easy to operate and service; controllers can be used with every laser head model and swapped within minutes while conserving constant performances.

The SNG series are designed for high average power, delivering multi-kW peak power at repetition rates up to 70kHz.

APPLICATIONS

- Material processing
 - Cost effective marking solutions
 - Graphitization
- Instrumentation
 - Ranging
 - Differential absorption LIDAR
 - Super-continuum generation
 - Distributed temperature sensing
 - Raman spectroscopy
- Biophotonics
 - Nanosurgery
 - Protein cross-linking

TECHNICAL SPECIFICATIONS

	SNG-03E-100	SNG-20F-100	SNG-40F-100	SNG-50F-100	SNG-70F-100 ⁽⁶⁾ *	SNG-100P-100	SNG-150P-100 [*]
Wavelength	532nm	532nm	532nm	532nm	532nm	532nm	532nm
Repetition Rate	>5kHz	>19kHz	>35kHz	≥45kHz	>65kHz	>20kHz	>28kHz
Constant Pulse width range (FWHM)⁽¹⁾	<0.75ns	<0.75ns	<0.75ns	<0.65ns	<0.55ns	<0.85ns	<0.75ns
Output power⁽²⁾	>15mW	>48mW	>52mW	>45mW	>13mW	>100mW	>140mW
Output energy	>3μJ	>2.5μJ	>1.5μJ	>1μJ	>0.2μJ	>5μJ	>5μJ
Peak Power	>4kW	>3kW	>2kW	>1.5kW	>0.35kW	>7kW	>7kW
Short term (10min) power stability⁽³⁾	<±1%	<±1%	<±1%	<±1%	<±1%	<±2%	<±2%
Long term (6 hrs) power stability⁽³⁾	<±3%	<±3%	<±3%	<±3%	<±3%	<±3%	<±3%
Beam profile	Gaussian TEM00	Gaussian TEM00	Gaussian TEM00	Gaussian TEM00	Gaussian TEM00	Gaussian TEM00	Gaussian TEM00
Full angle divergence							
Horiz. @1/e²	10±2 mrad	10±2 mrad	10±2 mrad	11±2 mrad	<14 mrad	4.2±1 mrad	TBD
Vert. @1/e²	9±2 mrad	9±2 mrad	9±2 mrad	11±2 mrad	<14 mrad	4.2±1 mrad	TBD
M²⁽⁴⁾	<1.3	<1.3	<1.3	<1.3	<1.3	<1.25	<1.3
Beam ellipticity⁽⁵⁾	<1.3	<1.3	<1.3	<1.3	<1.3	<1.2	<1.2
Polarization	Linear PER>20dB	Linear PER>20dB	Linear PER>20dB	Linear PER>20dB	Linear PER>20dB	Linear PER>20dB	Linear PER>20dB
Package dimensions	115x29x35 mm	145x42x35 mm	145x42x35 mm	145x42x35 mm	145x42x35 mm	145x42x35 mm	145x42x35 mm
Package weight	250g	300g	300g	300g	300g	300g	300g
Options (table p3)	-	S	S	S	S	S	S

* The specifications will be confirmed after the Beta phase only. For the moment, the specifications are preliminary, which means that the final laser parameters might be different than the current specifications.

NOTES

- (1) Measured with 1GHz photodiode and 1GHz/10GS/s oscilloscope
- (2) Measurement performed with an OPHIR thermal power sensor (OPHIR 3A-FS-SH)
- (3) For temperature variation < ± 3°C and < 3°C/hour, stability is measured with calorimeter - detector band [DC, 2Hz]
- (4) Mean average value $M = \sqrt{(XY)}$, X and Y being respectively the major and minor axis of the ellipse
- (5) Beam ellipticity is calculated as the ratio of the main axis far field divergence
- (6) Contact factory for availability

COMPLEMENTARY INFORMATION & OPTIONS

Environment Parameters	
Operating Temperature Range	0-50°C
Maximum Laser Head Baseplate Temperature	<50°C
Maximum Power Consumption	<40W
Laser Head Thermal Dissipation	<15W
Storage Temperature	0-50°C
Shock of 11ms according to IEC 68-2-27, non operating	25g
Vibration 5Hz to 500Hz sinusoidal according to IEC 68-2-6	2g

Certification	
Laser classification according to IEC 60825-1:2007	3B
CDRH	Yes, if used with a -DR1 controller
RoHS	Yes

Options	
Synchronization output (S)	TTL compatible output signal for synchronization/monitoring

Available Controller Types				
Model for the SNG-150P-100	Model for the other SNG lasers	Type	Input Power	CDRH
MLC-05A-DR1	MLC-03A-DR1	Desktop	100-240 V AC	Yes
MLC-05A-MR1	MLC-03A-MR1	Module	12 V DC	No
MLC-05A-BR1	MLC-03A-BR1	Board	12 V DC	No

CDRH LASER HEAD MECHANICAL DRAWINGS: SNG-20F-100, SNG-40F-100, SNG-50F-100, SNG-70F-100, SNG-100P-100 & SNG-150P-100

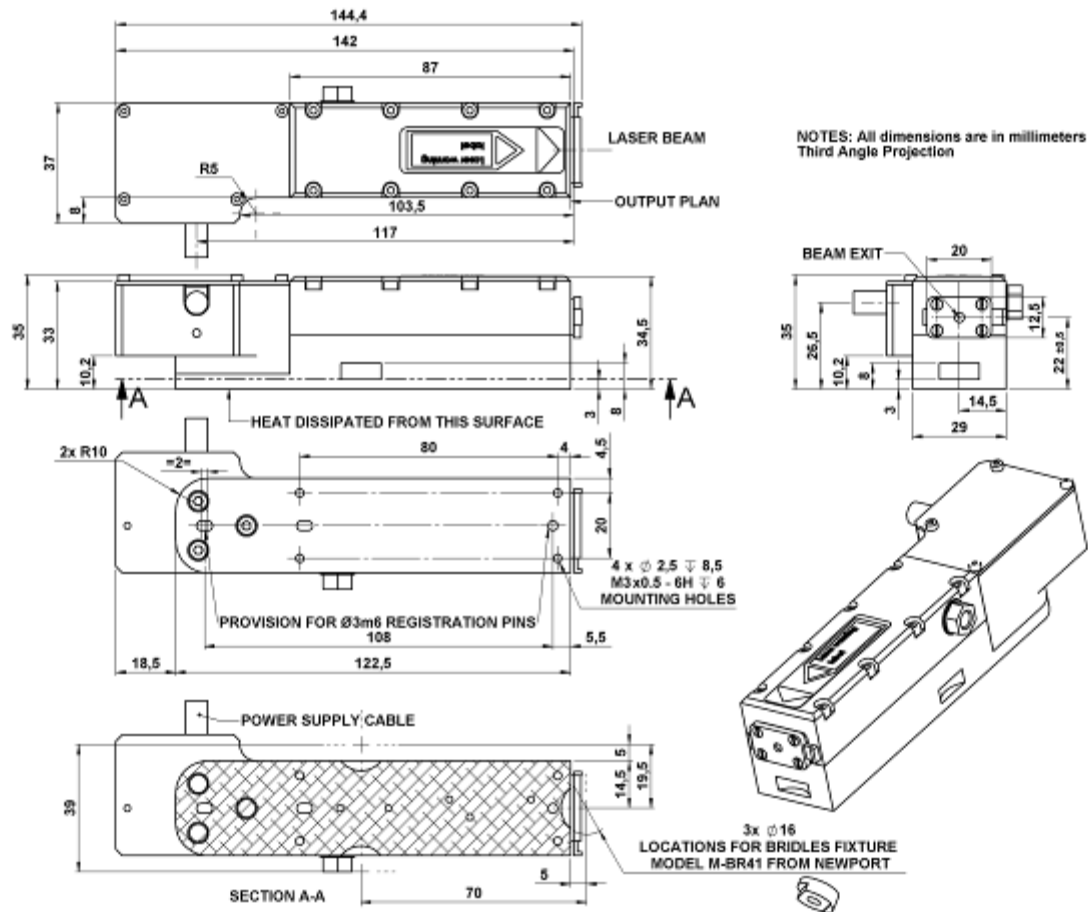

CDRH LASER HEAD MECHANICAL DRAWINGS: SNG-03E-100

