

PLANAR GLASS LASER PRODUCTS

1.53 μ m PM-PGL laser series

The PM-PGL laser module is based on the DFB planar erbium-doped-glass technology. It presents a single frequency operation above 1.53 μ m wavelength, at the output of a PM single-mode fibre. Its key features are a very narrow line-width of 10kHz, and a low noise signal with a RIN below -140dB/Hz, for 10mW of CW output power.

It is designed for application requiring high wavelength stability and low noise, together with single spatial and single longitudinal mode, as well as fibre delivery in a compact environment.

The PGL laser module is manufactured using Teem's proprietary glass waveguide technology and complies to Telcordia GR 1312 industry standards for reliability, performance, and robustness.



Application

- High quality seed for high power fibre amplifier
- Low-noise source for Lidar and sensor application
- Narrow line-width for highly efficient non-linear optical application
- Narrow line-width and single frequency for high resolution spectroscopy
- Long coherence length for interferometry application

Feature and benefit

- Low Relative Intensity Noise (RIN) of -140dB/Hz above 5MHz
- Narrow spectral line-width of 10kHz
- Long coherence length of 30km
- Very good thermal stability of 0.01nm/°C (improved stability achievable with a TEC)
- 10dBm output power, for less than 1W of electrical power
- Compact: 81mm x 35mm x 12mm
- PM and non-PM SMF fibre delivery, single spatial mode
- Eye safe operation in the 1.53 μ m wavelength range
- Compatibility with laser array design
- Optional electronic board for pump control, 3.3V operation

Optical performance

Parameter	Performance
Wavelength	1530 – 1560 nm
Wavelength knowlegde accuracy	$< 7 \times 10^{-6}$
Wavelength stability	0.01nm/°C
Output power	10 mW
Power stability	< 10 %
Side mode suppression ratio	> 60 dB
Polarisation extinction ratio	> 20 dB
Laser Linewidth	10 kHz
Relative Intensity Noise	< - 140 dB/Hz (for f > 5 MHz)

Mechanical and Electrical

Parameter	Performance
Dimension (W x L x H)	81 x 35 x 12 mm ³
Electrical connector	Direct contact, 16 pins
Power consumption	< 1 W
Max supplied current	500 mA
Operating temperature	10 to 50 °C
Storage temperature	-40 to 85 °C

Pin Assignment

Pin	Description
1	NC
2	NC
3	NC
4	NC
5	Pump thermistor (optional)
6	Pump thermistor (optional)
7	Ground
8	Pump photodiode anode (optional)
9	NC
10	Pump photodiode cathode (optional)
11	Output signal photodiode anode (optional)
12	Output signal photodiode cathode (optional)
13	NC
14	NC
15	Pump laser cathode
16	Pump laser anode

Mechanical Specification

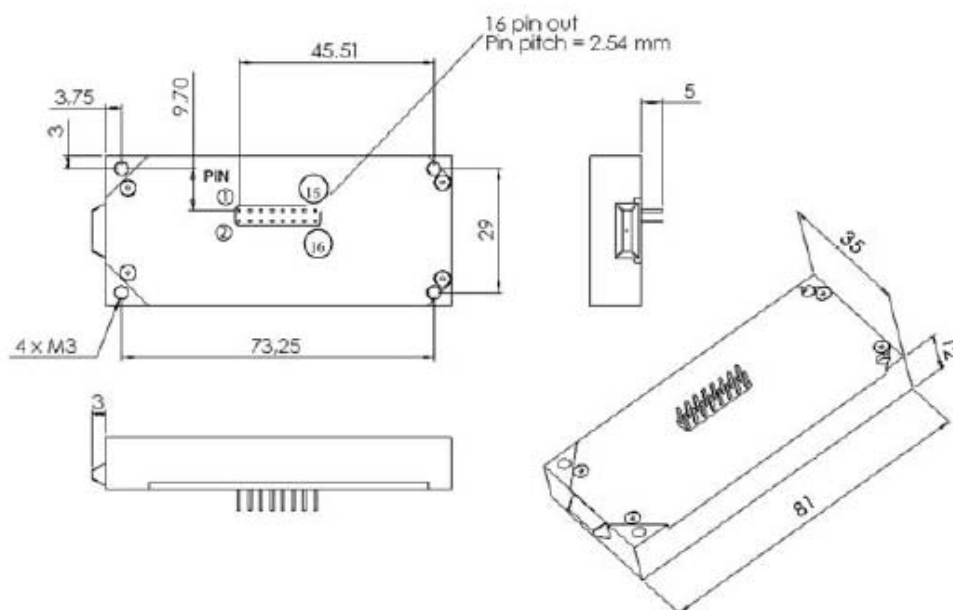

Ordering

To place an order or obtain additional information, please contact a sales representative:

North & South America : Tel : +1 408-935-8390

Europe, Middle-east, Asia : Tel : +33 (0) 476 04 03 09 – Fax : +33 (0) 476 04 03 02

Email : sales@teemphotonics.com

All information contained herein is believed to be accurate and is subject to change without notice. Teem Photonics may not be held liable for its use. Teem Photonics, its subsidiaries and affiliates, reserve the right to modify or withdraw, at any time and without any notice, specifications, product design, product component. Some options may not be available for all products. Please contact Teem Photonics for details. May 2008 – V0.1.

